

产品规格说明书

HXDB01-WLP-A1 单相浸水防触电断路器

Product specification sheets

HXDB01-WLP-A1 single-phase water immersion anti-touch circuit breaker



一、产品介绍

Product introduction

HXDB01-WLP-A1 适用于交流额定频率 50Hz，额定电压不超过 240V，额定电流不超过 100A，额定短路能力不超过 6000A；可安装在智能电表测量系统、通讯基站、光伏并网、工业控制、建筑设备、智能家居、智能办公楼宇、路灯控制系统、学校、医院等配电线路，可进行远程控制分闸，也可人工合分闸，并具有过载、短路、浸水防触电、剩余电流保护功能，家用或类似用途的用电场所。

HXDB01-WLP-A1 is suitable for AC rated frequency 50Hz, rated voltage not exceeding 240V, rated current not exceeding 100A, rated short-circuit capacity not exceeding 6000A. It can be installed in intelligent meter measuring systems, communication base stations, photovoltaic grid-connected, industrial control, construction equipment, intelligent homes, intelligent office buildings, street light control systems, schools, hospitals and other power distribution lines, and can for remote control of the switch-off, or manual closing and dividing, and with overload, short-circuit, immersion against electric shock, residual current protection, for household or similar purposes in places where electricity is used.

- **漏电保护：**本产品可以实时监测线路漏电情况，漏电值达到设定值时，设备会自动断闸并记录问题详情。
- **Leakage protection:** This product can monitor line leakage in real time, and when the leakage value reaches a set value, the device will automatically break and record the details of the problem.
- **过温保护：**实时监测线路温度，当线路温度达到设定值时，设备会自动断闸并记录问题详情。
- **Over-temperature protection:** The line temperature is monitored in real time and when the line temperature reaches a set value, the device will automatically break and record details of the problem.
- **过/欠压保护：**实时监测线路电压数据，当线路电压超过/低于设定值，设备会自动断闸并记录问题详情。
- **Over/under voltage protection:** Real-time monitoring of line voltage data, when the line voltage is over/under the set value, the device will automatically break and record details of the problem.
- **电流过载自动断闸：**实时监测线路电流数据，当线路出现过载现象时，设备会自动断闸并记录问题详情。
- **Automatic current overload cut-off:** real-time monitoring of line current data, when the line is overloaded, the device will automatically cut-off and record details of the problem.
- **缺相自动断闸：**当线路发生缺相情况，设备会自动断闸并记录问题详情。
- **Automatic phase loss break:** When a phase loss occurs on the line, the device will automatically break and record details of the problem.
- **功率因素数据分析：**后台能实时分析功率因素数据。
- **Power factor data analysis:** the back office can analyse power factor data in real time.

- **电度计量：**后台能实时看到用户用电量。
- **Electricity metering:** the back office can see the customer's electricity consumption in real time.
- **时间设定断闸：**能设定定时断闸功能。
- **Time set to break:** The ability to set a timed break function.
- **浸水防触电：**接入本产品线路的设备遇到浸水，不会发生触电危害。
- **Water immersion protection against electric shock:** Equipment connected to the product line will not be exposed to electric shock if it encounters water immersion.

工作原理

Working Principle

本产品工作原理，主要利用电子，电气学原理，当用电设备或线路发生浸水时，通过设备内置的 MCU 芯片上的电子原件立即开启屏蔽和吸收泄漏电流，对电流进行分流到 PE 线通向大地，实现等电位。减少对人体的触电伤害。

The principle of operation of this product, mainly using electronic and electrical principles, when the use of electrical equipment or wiring in the event of water immersion, the electronic element on the MCU chip in the device immediately switches on the shield and absorbs the leakage current, shunting the current to the PE line to earth and achieving equipotential, so that reduces the risk of electric shock to the human body.

产品功能

Product Features

1. 具有信息短信、电话、微信推送、平台端推送功能。
1. With information SMS, phone, WeChat push and platform side push functions.
2. 漏电保护
2. Earth leakage protection
3. 过温保护
3. Over temperature protection
4. 过载保护
4. Overload protection
5. 短路保护
5. Short circuit protection
6. 电度计量
6. Electricity metering
7. 过/欠压保护
7. Over/under voltage protection
8. 防浪涌
8. Anti-surge
9. 浸水保护
9. Water immersion protection

- 10. 功率因素分析
- 10. Power factor analysis
- 11. 远程分闸
- 11. Remote gate splitting

产品应用场所

Product application areas

本产品可适用于智慧消防项目，九小场所消防改造项目。如学校、医院、寺庙、会展、宾馆、娱乐场所、商场、住宅、仓库、电动车充电站及工厂等。此产品亦可向石油、化工、汽车、轮船、航空等领域作电气防火的延伸开发。

This product can be applied to intelligent fire fighting projects, nine small places fire fighting transformation projects. such as schools, hospitals, temples and exhibitions, hotels, entertainment venues, shopping malls, houses, warehouses, electric vehicle charging stations and factories. It can also be developed as an electrical fire protection extension for petroleum, chemical, automobile, ship and aviation fields.

二、技术参数 Technical Parameters

参数 Parameters	指标 Indicators
额定工作电压 Rated working voltage	220VAC 50HZ
额定电流壳架等级 Rated current shell frame class	100A
短路分段能力 Short circuit segmentation capability	$I_{cs}=I_{cu}=6000A$
产品防护等级 Product protection class	IP20
工作环境温度 Operating ambient temperature	-40-70° C
漏电保护整定值设置 Leakage protection setting	10-100mA 可设置 10-100mA configurable
电流过载保护 Current overload protection	10-100A
过压保护 Overvoltage protection	250-320V 可设置 250-320V settable



欠压保护 Undervoltage protection	100-200V 可设置 100-200V settable
超温保护 Over temperature protection	0-120℃可设置 0-120° C settable
漏电保护动作 Earth leakage protection action	0.04s
短路保护动作 Short circuit protection action	0.03s
浸水保护 Water immersion protection	浸水后 10-990S 后跳闸保护设定 Trip protection setting after 10-990S of water immersion
通讯方式 Communication methods	RS485

三、产品说明

Product Description

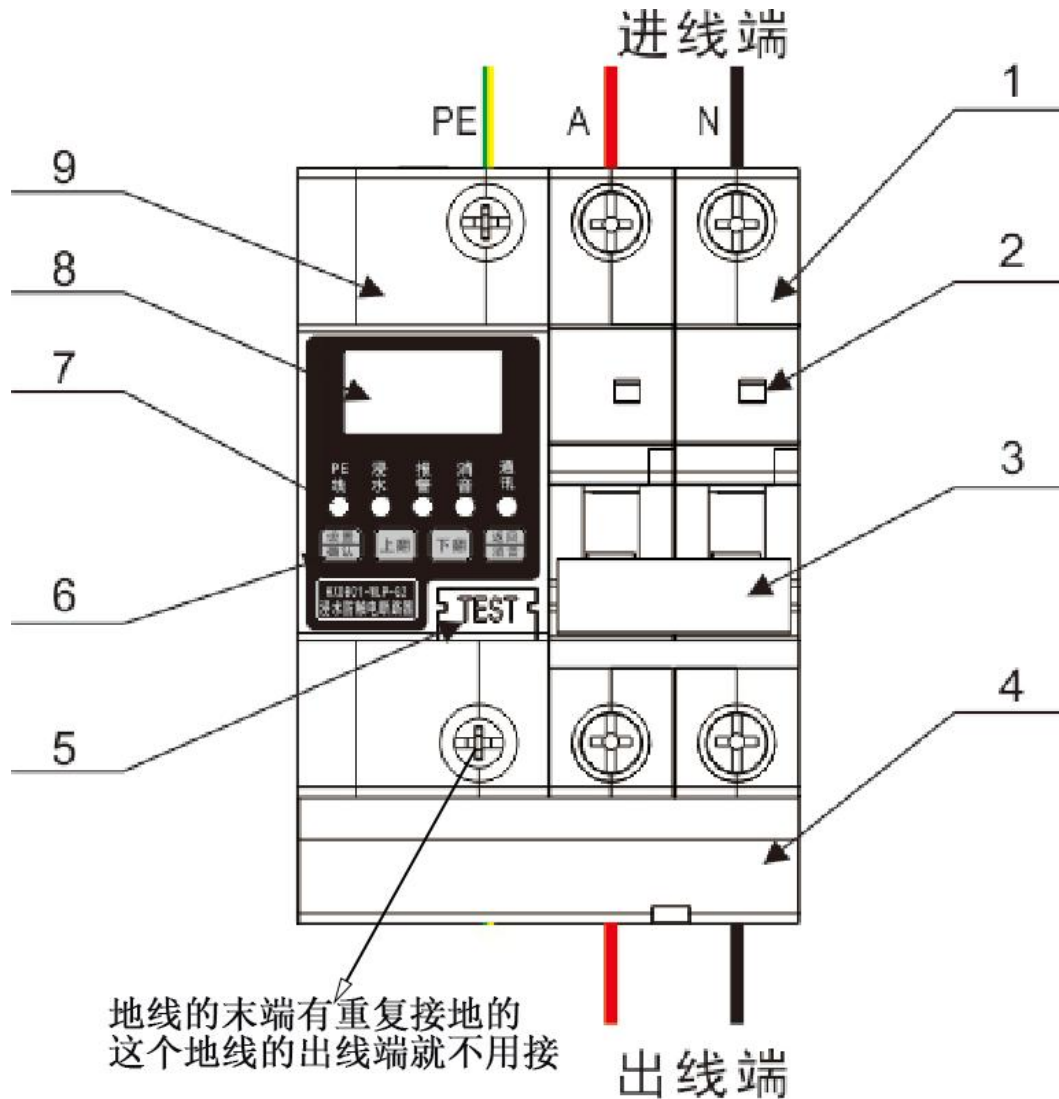

1. 断路器本体;起到电流通断和短路、过载保护作用;
 Circuit breaker body; plays the role of current interruption and short-circuit and overload protection.
2. 断路器触头指示;指示断路器状态,红色:合闸,绿色:分闸
 Circuit breaker contact indication; indicate the state of the circuit breaker, red: closed, green: split
3. 操作手柄;手动推动手柄,可控制断路器合分状态
 Operation handle; manually push the handle, can control the circuit breaker closed and divided state
4. 计量、漏电检测模块:主要检测电流,电压采样,漏电信号及接线端子温度信号等。
 Metering, leakage detection module: mainly detects current, voltage sampling, leakage signals and terminal temperature signals.



5. 漏电试验按钮;主要检测漏电功能是否失效,每月需自检按一次,开关能正常分闸证明开关漏电功能正常。

Leakage test button; mainly to detect whether the leakage function is invalid, once a month you need to press the self-test, the switch can be normally divided to prove that the leakage function of the switch is normal

6. 本地设置和查看按键

Local setting and viewing of keys:

(1) 功能按此键进入菜单;参数设置后再按此键确认输入。

(1) Press this key to enter the menu. After setting the parameter press this key again to confirm the input.

(2) 上按此键一次光标向上跳动一行;进入设置状态,每按一下,数字往上递增。

(2) Press this key once to jump the cursor up one line. Enter the setting state, each press increments the number upwards.

(3) 下按此键一次光标向下跳动一行;进入设置状态,每按一下,数字往下递减

(3) Press this key once to jump the cursor down one line; enter the setting state, each time you press it, the number goes down in increments

(4) 在设置或查看状态,按此键一次,返回上级菜单;如开关在故障声音报警状态,按此键,可以消除报警声音

(4) Press this button once in the setting or viewing state to return to the upper menu. If the switch is in the fault sound alarm state, press this button to cancel the alarm sound.

7. 状态指示灯

Status indicator

(1) PE线:如前端PE线接入正常,指示灯绿色常亮;如未接入,指示灯不亮,同时有声音
PE line: if the front PE line is connected normally, the indicator light is always green; if it is not connected, the indicator light does not light up, and there is sound at the same time

(2) 报警,在显示屏上会显示“PE线断开报警”;

Alarm, "PE line disconnection alarm" is shown on the display.

(3) 浸水:如后端保护负载发生浸水,指示灯红灯常亮,同时有声音报警,在显示屏上会显示“浸水报警”并开关分闸开始倒计时

Flooding: If the back-end protection load is flooded, the red light of the indicator light will always be on, and there will be an audible alarm. The "Flooding Alarm" will be displayed on the display screen and the switch will start to count down.

(4) 报警:开关发生故障时,指示灯红色常亮;消除故障后,指示灯不亮

Alarm: When the switch is faulty, the indicator light is always red; when the fault is removed, the indicator light does not light up

(5) 消音:开关发生故障后,有声音报警时,按键后,消除声音报警,同时指示灯常亮

Silencing: When there is an audible alarm after the switch has failed, press



the key to remove the audible alarm and the indicator light will always be on

(6) 通讯: 在接入 RS485 通讯时, 指示灯红色常亮;

Communication: The indicator light is always on in red when RS485 communication is connected.

三、产品尺寸

Product size

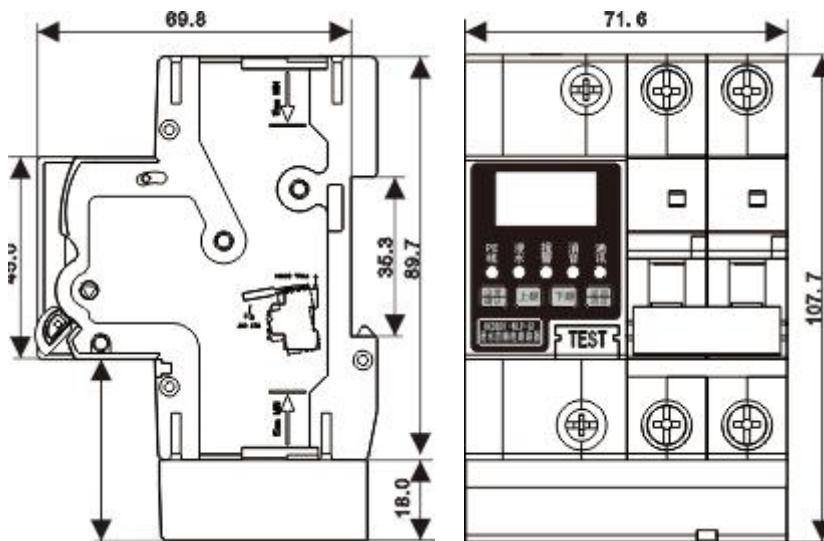

四、常见问题及解决方法

Common problems and solutions

<p>问题描述 Description of the problem</p>	<p>设备上电后, 排插放水里直接跳闸。 When the equipment is powered on, the plug will trip directly when it is placed in the water .</p>
<p>解决办法 Solutions</p>	<p>检查设置是否正确; 检查PE线是否正确接入。 Check that the settings are correct; check that the PE cable is correctly connected</p>
<p>问题描述 Description of the problem</p>	<p>上电后, 指示灯不亮。 Indicator lamp does not light up after power up</p>

解决办法 Solutions	检查电源接口是否接反，开关电源输出是否有电。 Check whether the power supply interface is connected backwards and whether the switching power supply output has power
问题描述 Description of the problem	设备合不上闸 Equipment does not close
解决办法 Solutions	请确保设备处于正常运行模式，其次再检查设备是否发生短路，过流等故障，当故障排除后，1 分钟后手动合闸。 Please ensure that the equipment is in normal operating mode, then check the equipment for short-circuit, overcurrent and other faults, and when the faults are removed, close the gate manually after 1 minute.

五、售后服务内容

After-sales service content

1、现场隐患评估与安装服务

Site hazard assessment and installation services

对企业及单位进行电气安全隐患现场评估，提出电气安全隐患监管建议，并根据实际情况提供“智慧用电”的安装服务。

We conduct on-site assessments of electrical safety hazards, make recommendations for the supervision of electrical safety hazards and provide installation services for "smart electricity" according to the actual situation.

2、隐患监管与排查服务

Hidden Hazard Supervision and Detection Service

已安装“智慧安全用电系统”的企业及单位提供 7*24 小时全天候线上隐患及排查值守服务，通过监管大屏幕实时发现安装单位存在的电气安全隐患，并通过预警短信推送、电话告知、现场排查、隐患解决方案等措施，实现精准隐患监督及精准隐患线路的整改，最终达到消除电气安全隐患的目的。

The enterprises and units that have installed the "Smart Safety Electricity System" provide 7*24-hour online hidden danger and investigation guard services, through the supervision of the large screen real-time discovery of the existence of hidden electrical safety hazards in the installation unit, and through early warning SMS push, telephone notification, on-site investigation, hidden danger solutions and other measures to achieve precise hidden danger supervision and The purpose of eliminating hidden electrical safety hazards is ultimately achieved through the rectification of precise hidden lines.

3、电话指导服务

Telephone guidance service

服务团队在 7*24 小时值守的同时，向用电企业及单位提供电话咨询服务，协助分析可能存在的隐患并提供隐患排查思路，必要时提供现场指导与现场隐患排查服务。

The service team is on duty 24 hours a day, 7*7, to provide telephone advisory services to power companies and units, assist in analysing possible hidden dangers and provide ideas for hidden dangers, and provide on-site guidance and on-site hidden dangers investigation services when necessary.

4、系统维护

System maintenance

提供“智慧安全用电系统”设备及系统的日常维护工作，确保“智慧安全用电系统”设备及系统的正常运行。

Provide daily maintenance of the "Smart Electricity Safety System" equipment and systems to ensure the normal operation of the "Smart Electricity Safety System" equipment and systems.

5、培训服务

Training services

采用“一对一”现场培训与集中培训相结合的方式，使得最终用户能熟练使用产品设置功能、“智慧用电”小程序、手机 APP、电脑端操作，在培训过程中，也起到提升用户用电安全的意识。

By combining "one-on-one" on-site training with centralized training, end users can skillfully use product setting function, "smart electricity" applet, mobile phone APP and computer-side operation, and during the training process, it also plays a role in enhancing users' awareness of electricity safety.

七、保险服务

Insurance service

该产品已经向中国人民保险公司购买了产品责任险。（产品责任险每年签约的保险公司可能不同。）：

This product has purchased product liability insurance from China People's Insurance Company. (Product liability insurance may be signed by different insurance companies every year.)：

- 1、每次事故赔偿限额 1300 万，累计赔偿限额 1500 万
The compensation limit for each accident is 13 million, and the cumulative compensation limit is 15 million.
- 2、每次事故财产损失赔偿限额 500 万
The compensation limit for property losses per accident is 5 million.
- 3、每次事故人身伤亡赔偿限额 500 万
The compensation limit for personal injury and death in each accident is 5 million.
- 4、每次事故每人人身伤亡赔偿限额 150 万元
The compensation limit for personal injury and death per person per accident is 1.5 million yuan.
- 5、赔偿情况可能随着每年续签情况会有所变化，以最新为准。
The compensation situation may change with the annual renewal, whichever is the latest.
- 6、保险承保范围为中国大陆地区（香港，澳门，台湾除外）
The insurance coverage is in Chinese mainland (except Hongkong, Macau and Taiwan Province).

八、联系方式

Contact us

Guangdong Province Hengxiang Security Technology Co., Ltd

Website: www.hxkj119.cn

Email: hxkj_119@163.com

Service Hotline: 400-7655-119

[Tel: \(+86\) 0755-2972-8368](tel:+86075529728368)

Address: Building 2, Nam Tai Inno Valley, Guangming Avenue, Guangming District, Shenzhen, Guangdong Province, China